

# Wiring Diagram

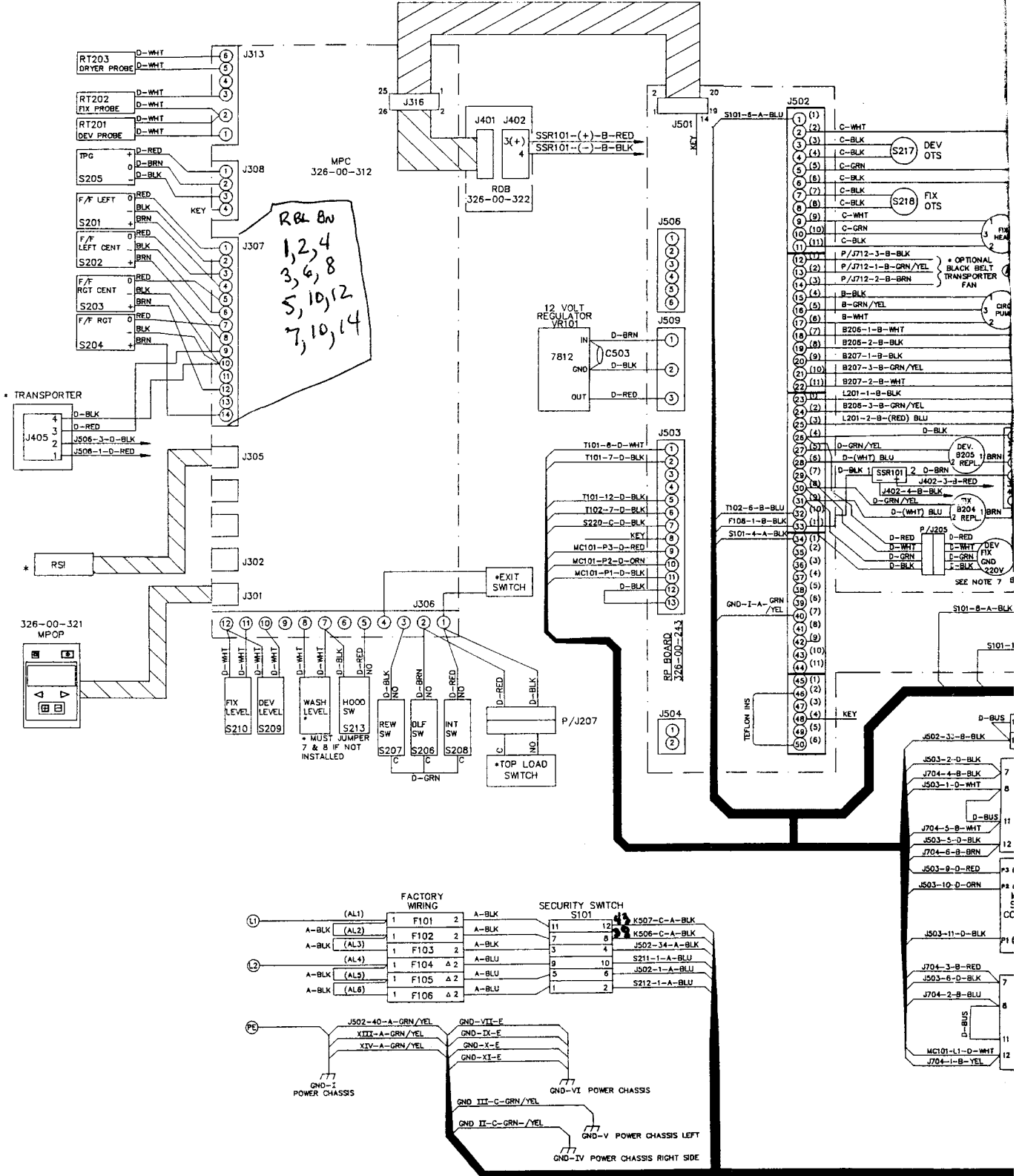

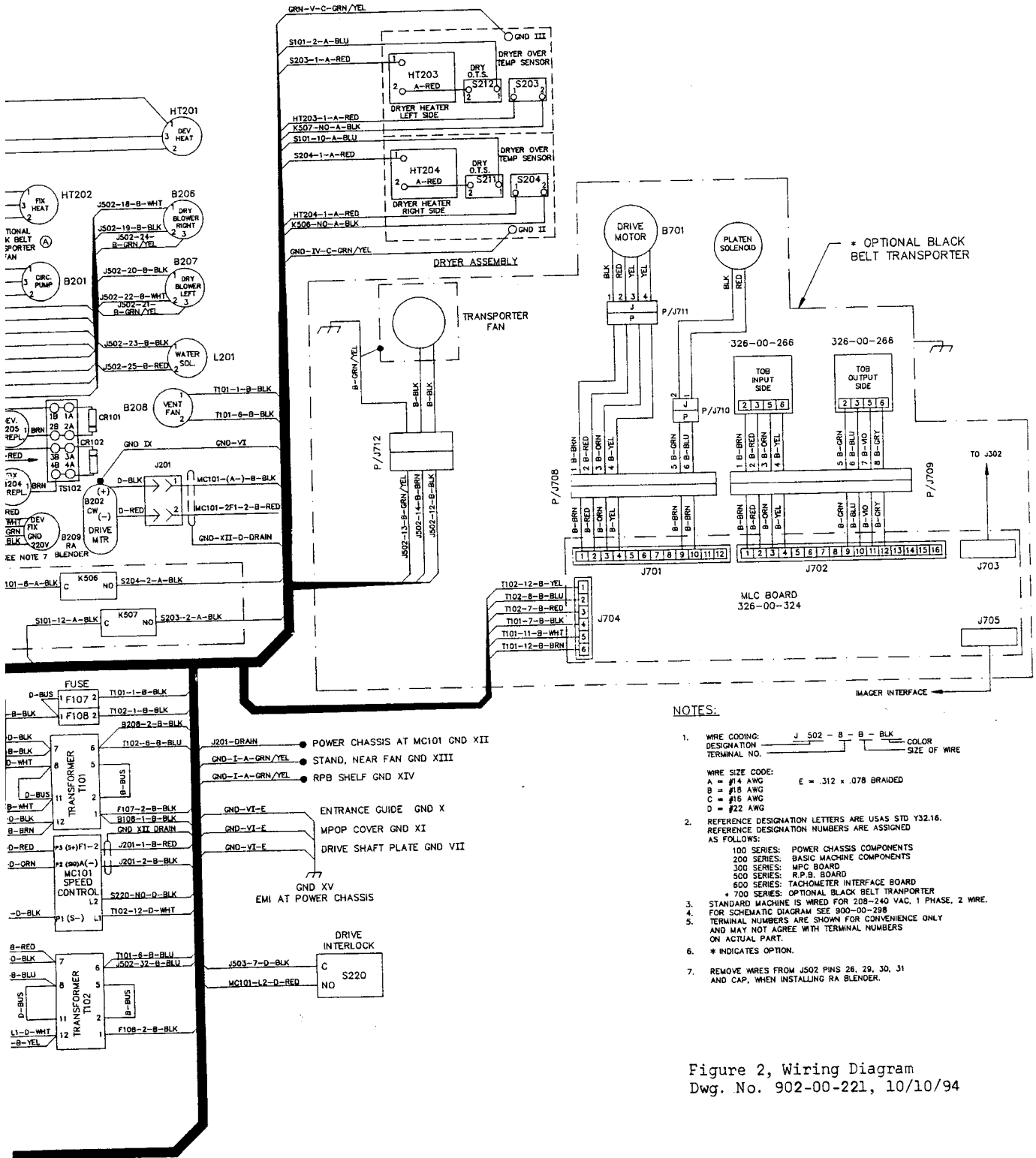

- NOTES:**
- WIRE CODING: J 502 - B - B - BLK COLOR SIZE OF WIRE
  - REFERENCE DESIGNATION LETTERS ARE USAS STD Y32.16. REFERENCE DESIGNATION NUMBERS ARE ASSIGNED AS FOLLOWS:
    - 100 SERIES: POWER CHASSIS COMPONENTS
    - 200 SERIES: BASIC MACHINE COMPONENTS
    - 300 SERIES: MPC BOARD
    - 500 SERIES: R.P.B. BOARD
    - 600 SERIES: TACHOMETER INTERFACE BOARD
    - \* 700 SERIES: OPTIONAL BLACK BELT TRANSPORTER
  - STANDARD MACHINE IS WIRED FOR 208-240 VAC, 1 PHASE, 2 WIRE.
  - FOR SCHEMATIC DIAGRAM SEE 900-00-298
  - TERMINAL NUMBERS ARE SHOWN FOR CONVENIENCE ONLY AND MAY NOT AGREE WITH TERMINAL NUMBERS ON ACTUAL PART.
  - \* INDICATES OPTION.
  - REMOVE WIRES FROM J502 PINS 26, 29, 30, 31 AND CAP, WHEN INSTALLING RA BLENDER.

Figure 2, Wiring Diagram  
Dwg. No. 902-00-221, 10/10/94