

SOLID STATE RELAY KIT L975-00-973

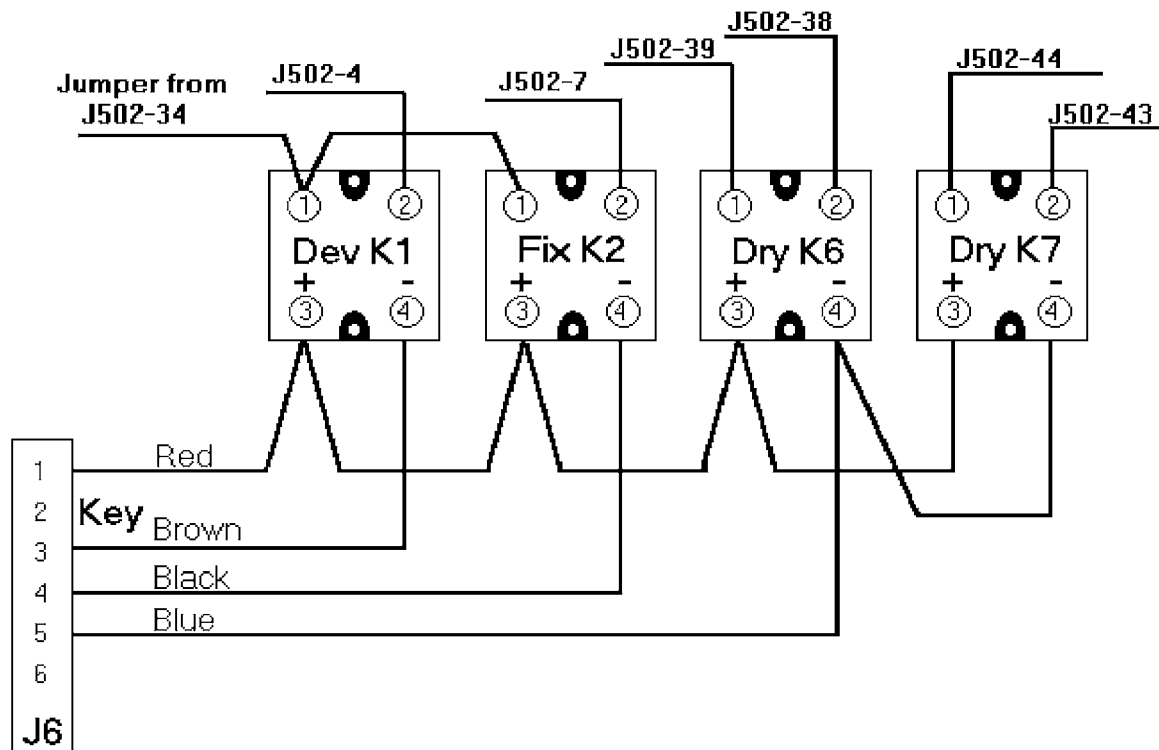

This kit comes pre-wired to the plug for J506 as shown.

1. Remove wires 36 and 37 from the Relay Power Board (RPB) and splice the wires together.
2. Remove wires 41 and 42 from the RPB and splice the wires together.

(On a processor where the heater wires are connected directly to the relays steps 1 and 2 have already been done.)
The location of the new relays will vary depending on the version of the power chassis in your processor.

3. In the older chassis there is space to mount all four relays in the back left corner (two on the left and two on the back). Apply a layer of heat sink compound to the back of each relay and attach the relays to the chassis wall with #6 or M4 hardware.

3a. In the new chassis (where the RPB is attached to a hinged plate) mount the DEV and FIX relays to the back left hand side of the power chassis and the DRYER relays to the under side of the RPB plate (again on the left side). Remove the RPB from the plate and the plate from its hinges. Then drill through both the plastic and aluminum plates to mount the relays. Use heat sink compound and install screws at both ends of the relays.

4. The tie wraps on the wire harness can be cut to get enough wire length to reach the load side of the relays. If necessary, splice additional wire to the existing wire. Terminate each wire with a spade connector. **Note:** A jumper wire is added from J502-34 to terminal 1 on the DEV relay. All other wires are removed from J502 then connected to the relay.

5. Remove jumpers J5, J7, and J8 from the RPB.

NOTE: If you are working with a processor that is on-line to a Dolev there are already black and red wires attached to a plug at J6 on the RPB. Remove these from the old plug and connect them in parallel with wires 1 and 4 on the new plug.