

Interface Board Adjustment Points

- T-1 Motor Speed Max
- T-2 Fix Temp
- T-3 Dev Temp
- T-4 Motor Speed Min

Multicontrol Board Adjustment Points

- T-1 Saver Time
- T-2 OXI Amount
- T-3 OXI Interval
- T-4 Dev Repl Amount
- T-5 Fix Repl Amount

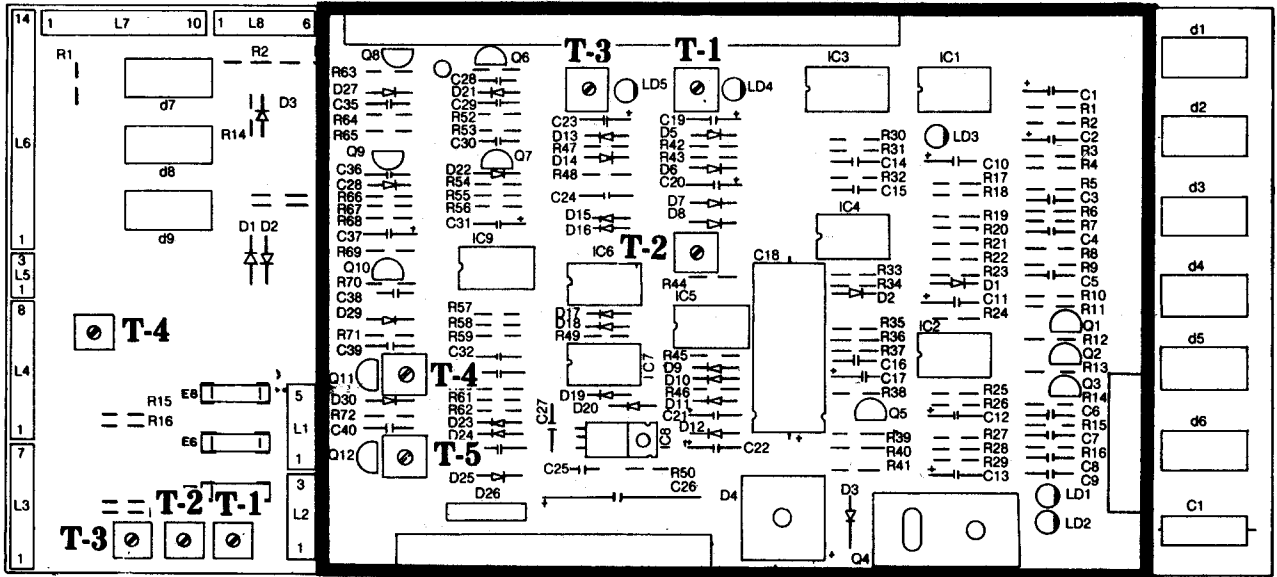

Figure 12. Early Style Interface & Early Style Multicontrol Board Calibration Points

Interface Board Adjustment Points

- T-1 Motor Speed Max
- T-2 Fix Temp
- T-3 Dev Temp
- T-4 Motor Speed Min
- T-5 & T-6 IR Sensors (late style boards only)
- T-7 Not Used

Multicontrol Board Adjustment Points

- T-1 Saver Time
- T-2 OXI Amount
- T-3 OXI Interval
- T-4 Dev Repl Amount
- T-5 Fix Repl Amount

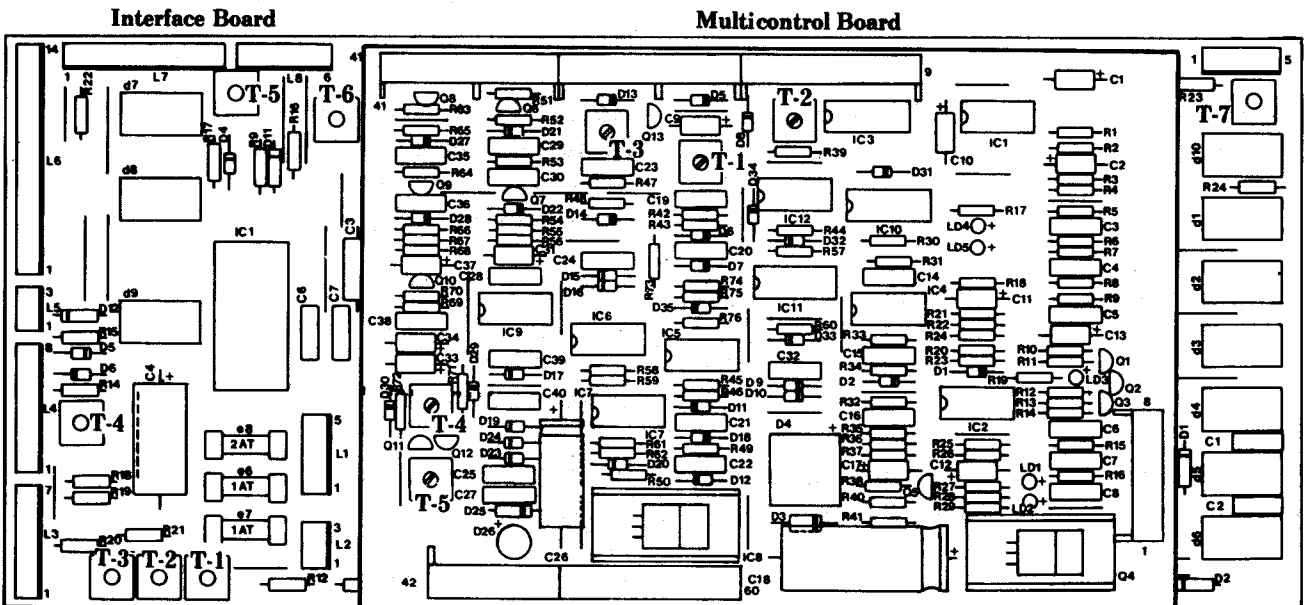

Figure 13. Late Style Interface and Late Style Multicontrol Board Calibration Points

Service Information, LOGELINE-17A

Multicontrol Board Pin Voltages

Test Across Pins: Control Circuit Power Supply

- 46 47** 15 VAC nominal input from transformer m-1. If 15 VAC is not present, check fuse e-7; then trace connections back to transformer secondary and primary. If 220 VAC nominal is not at primary, check incoming power at TS-1-22 and TS-1-23. If 220 VAC is at terminal strip but not at transformer, check fuses e-1 and e-9.
- 48 45** 18 VDC nominal unregulated supply for the d-relay coils. If 18 VDC is not present, check for 15 VAC across pins 46 and 47 (see above). If 15 VAC is present, but there is not 18 VDC on pin 45, then suspect fault on Multicontrol Board.
- 48 49** 18 VDC nominal. If 18 VDC is not present, check for 15 VAC across pins 46 and 47 (see above).
- 48 50** 12 VDC regulated supply for temperature reference, LED's, IR Film Feed Sensors, etc. If 12 VDC is not present, or is not stable, check for 15VAC across pins 46 & 47 as above. If 15 VAC is present, but there is no 12 VDC on pin 50, suspect faulty MCB.

Film Feed Sensor Circuit

- 48 41** EARLY STYLE MCB:
1 to 15 VDC as density control on front panel varies. If voltage not present or does not vary, check supply on pin 49 (see above), then check resistance of density control potentiometer on the Control Panel (100K ohm pot). Check resistors R-6, R-8, R-11, and R-16 (56 ohm) on Interface Board (remove L-7 for continuity check).
- LATE STYLE MCB:
10 to 11 VDC supply for the IR Transmitters. If not present, check supply on pin 45 (See above).
- 48 32** 1 to 10 VDC when right film feed sensor is blocked; 0 volts when unblocked. If 1 to 10 VDC not present, first check pin 41 (see above). If voltage on pin 41 is correct, then check for 12-18 VDC on L7-4 (supply for sensor). If sensor supply is present, suspect fault in film feed sensor or transmitter.
- 48 39** Same as for pin 32 but for left film feed sensor.

Service Information, LOGELINE-17A

Multicontrol Board Pin Voltages (Cont.)

Low = 0.5 to 0.8 VDC **High** = 10 to 12 VDC

Test across pins: **Film Feed Sensor Circuit (Cont.)**

- 48 33** Low when right film feed sensor is blocked; high when sensor is unblocked. If voltage stays high, check voltage on pin 32. If voltage is correct on pin 32 suspect fault on Multicontrol Board.
- 48 38** Same as pin 33 but for left film feed sensor.

Dev and Fix Temperature Control

- 48 8** 3 to 6.5 VDC; below 6 VDC signals DEV heat on. If voltage on pin 8 not changing with temperature, check supply for DEV temp probe on L3-3. If supply is correct, suspect fault in probe or DEV temp select potentiometer on front panel.
- 48 14** (READY LED must be on for this test.)
LOW signals DEV Heat On; HIGH signals DEV Heat Off. If voltage on pin 8 (see above) is below six volts and pin 14 is still HIGH, suspect fault on Multicontrol Board.
- 48 7** Same as pin 8 but for FIX temp.
- 48 12** Same as pin 14 but for FIX temp.
- 48 6** Not Used on *LogEline-17A*.
- 48 10** Not used on *LogEline-17A*
- 48 11** Inverse output from pin 8. Not Used on *LogEline-17A*.

Saver (Standby/Process) (READY LED must be on for this test.)

- 48 15** HIGH signals Standby; LOW signals Process. If pin 15 stays HIGH when film feed sensor is blocked, check voltage on pins 32 and 39 (see Film Feed Sensor Circuit). If voltage on pins 32 and 39 is correct, and signal on pin 15 does not change, suspect fault on Multicontrol Board.

If signal on pin 15 stays LOW, check Auto/Cont switch on front control panel and voltages on pins 32 and 39. If both are correct, suspect fault on Multicontrol Board. On early style MCB, LD-4 should always blink. On late style MCB, LD-4 may blink only when processing film

Service Information, LOGELINE-17A

Multicontrol Board Pin Voltages (Cont.)

Test Across Pins: **Low Level Detection Circuit**

- 49 3** 6 to 12 VAC incoming voltage for DEV Low Level Circuit. If voltage not present, check for open circuit between pin 3 and heater element ground (thru L3-5, low level probe and solution).
- 49 4** Same as pin 3 but for FIX Low Level Circuit.
- 49 5** Not used on 17A; tied to pin 4.
- 49 13** Signal LOW for normal condition. Goes HIGH when low level condition detected. If voltage correct on pins 3, 4 and 5, and signal is HIGH, suspect fault in d-7 relay or on Multicontrol Board.
- If signal LOW, but low level still exists, suspect fault on Interface Board.

Dev and Fix Replenishment

- 49 42*** HIGH signals DEV Replenishment pump on; LOW signals DEV Replenishment pump off. If film feed sensor is blocked and pin 42 never goes HIGH, check voltage on pins 32 and 39 (see Film Feed Sensor Circuit), voltage on pin 51 (see Drive Motor Control Circuit), and voltage on pin 30 (see below). If those voltages are correct, suspect fault on Multicontrol Board.
- Same as pin 42 but for FIX Replenishment Circuit.
- 49 43** When one film feed sensor is blocked, voltage on pin 30 will vary between .1 VDC and .75 VDC as the REPL RATE control is varied
- 49 30** (with two sensors blocked, it will vary between .2 VDC and 1.5 VDC). If voltage is incorrect, check voltage on pins 32 and 39 (See Film Feed Sensor Circuit) and REPL RATE control potentiometer on the front control panel. (Reading may not be stable on digital voltmeter.)
- (READY LED must be on for this test and OXI RATE front panel control potentiometer set at Position 4.)
- 49 16** LOW signals OXI REPL On; HIGH signals OXI REPL Off. If pin 16 never goes LOW, check OXI RATE control potentiometer on front panel. Also check to see if LD-5 is blinking. If not blinking, suspect fault on Multicontrol Board.

*On EARLY STYLE MCB, also check voltage on pin 41 (see film feed sensor circuit).

Service Information, LOGELINE-17A

Multicontrol Board Pin Voltages (Cont.)

Drive Motor Control Circuit

(For all tests in this section, READY LED must be on.)

- | | |
|--------------|--|
| 57 55 | 17 to 24 VAC nominal from transformer m-2. If 18 to 24 VAC is not present, check fuse e-8; then trace connections back to secondary and primary of transformer. If 220 VAC is not present at primary, check fuses e-2, e-9 and relay c-1. |
| 51 48 | Input reference for speed control: 3 VDC in standby; 2 to 11 VDC in process mode as developer speed control on front panel is varied. If voltage is not present, suspect a fault in developer speed control potentiometer or d-9 relay. |
| 52 59 | 3 to 20 VDC supply for drive motor. If 3 to 20 VDC is not present, check for 18 to 24 VAC across pins 55 and 57 (see above. If 18 to 24 VAC is present, but there is no voltage across pins 53 and 59, suspect fault in speed control section on Multicontrol Board. |

Service Information, LOGELINE-17A

Installation and Troubleshooting Adjustments

Problem Area	Adjust At	Procedure
Motor Speed	Interface Board	Adjust at MAX (15 sec) & MIN (120 inch feed times. MAX – Adjust T-1 for 24.5 sec. Per foot MIN - Adjust T-4 for 3 min. 18 sec. per foot or until drive motor just turns smoothly.
Replenisher Pump ON Cycle	Multicontrol Board	Set REPL RATE at 20, DENSITY % to 50%. Block both sensors and set below listed pots to obtain a 50ml draw of replenisher during each pump cycle. DEV - Adjust T-4, FIX - Adjust T-5 (Clockwise increases pump run time.)
Developer or Fix temp does not match setting	Interface Board	Set control to actual temp. Adjust below listed pots until LED on Multicontrol Board just comes on. DEV temp, adj. T-3 (Watch 3) FIX temp, adj. T-2 (Watch 2)
Saver Time Duration not Correct	Multicontrol Board	Set DEV TIME SECONDS at midrange, adjust T-1 until the processor changes to standby 15-30 seconds after material exits dryer. (Counterclockwise Increases time.)
Oxidation Time Interval incorrect	Multicontrol Board	Adjust T-3 so that when OXI control on front panel is set to "12", interval between cycle is 5 minutes. (Counterclockwise increases interval.)
Oxidation Rate not correct	Multicontrol Board	Adjust T-2 until desired amount is delivered during each ON cycle. (Factory set at 40ml.) (Clockwise increases pump run time.)
Dryer Temp not correct	Thermostat on Dryer Box	Set dryer to desired temp. Measure actual temp. Pry off lid of knob, loosen locking screw, and re-adjust pointer. Retighten locking screw.
Film Feed Sensor	Interface Board (Late Style Only)	For Late style sensors, adjust T-5 and T-6 for maximum sensitivity (fully counterclockwise). Turn clockwise if sensors activate when not blocked. For early style sensors set T-5 and T-6 to fully counterclockwise.

Service Information, LOGELINE-17A

Interface Board Relay Functions

- d-1 Controls coil of c-3 to turn on developer heater. Energizes when voltage on Pin 8 of MCB rises above 6 VDC.
- d-2 Controls coil of c-1 to turn on the cassette fan, the recirculation pumps and the drive motor. Energizes when d-7 is energized by the ON switch.
- d-3 Controls coil of c-2 to turn on fixer heater. Energizes when voltage Pin 7 of MCB rises above 6 VDC.
- d-4 Controls coil of c-6 to turn on developer replenishment pump for oxidation cycle only.
- d-5 Controls coil of c-6 to turn on developer replenishment pump for exhaustion cycle only. Energizes when voltage on Pin 43 of MCB goes high (12 VDC).
- d-6 Controls coil of c-5 to turn on fixer replenishment pump. Energizes when voltage on Pin 42 of MCB goes high (12 VDC).
- j
d-7 Power On relay. Supplies 12 VDC to coils of d-1, d-2, d-3, d-4, d-7, d-8 and d 9. Energizes when b-3 is switched to ON and latches if no "low level" condition exists. When b-3 is switched to OFF, latching circuit is broken.
- d-8 Controls coil of c-4 and c-7 to turn on dryer fans and heaters. Applies 24 VAC directly to wash water solenoid. Energizes when voltage on Pin 15 of MCB goes low (0.6 VDC), or when b-2 is switched to continuous process mode.
- d-9 Switches drive motor from standby speed to process speed. De-energized, d-9 applies a fixed voltage to the speed control. Energized, d-9 applies a voltage set by p-6 on front panel. Energizes when voltage on Pin 15 of MCB goes low (0.6 VDC), or when b-2 is switched to continuous process mode.

Notes: 1) MCB = Multicontrol Board

2) On late style Interface Boards d-10 is marked on circuit board but not used.

Service Information, LOGELINE 17A

Components within broken line are located on Motherboard & Multicontrol Board.

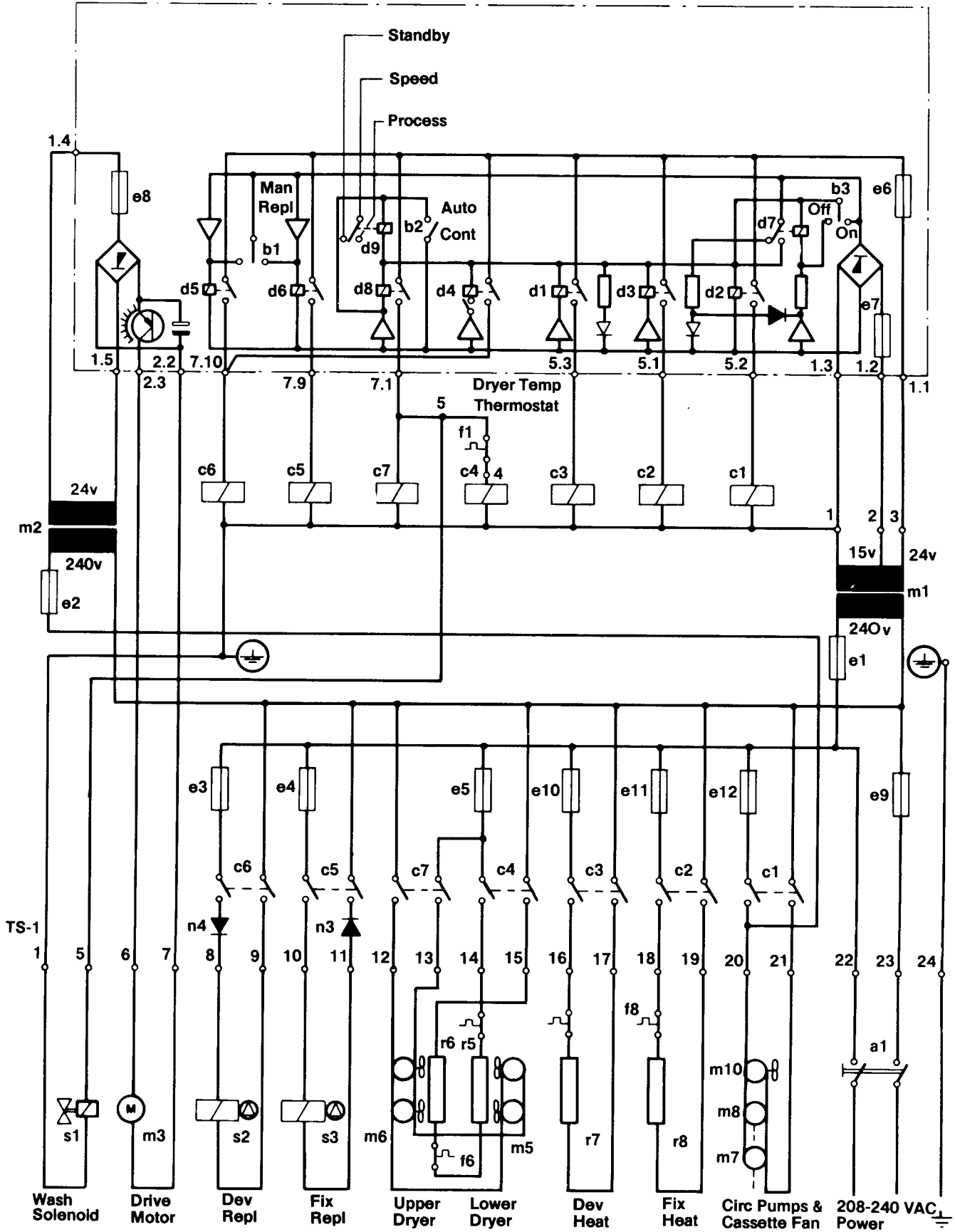

Figure 15. AC Power Diagram